

A111 Series

型番	入力	出力			形状	無負荷時消費電力	サイズ [mm]			EMC 規格
		電圧	電流	電力			D	W	H	
A111-2	90~264	5	2/2.2	10/11	Wall Mount		73	35	46	EN55022-B, EN61000-3-2,3, EN61000-4-2,3,4,5,6,8,11, FCC part 15 class B
A111-3							68	33	39	

安全規格

UL60950-1, CSA 22.2, IEC 60950-1, EN 60950-1

A111-2

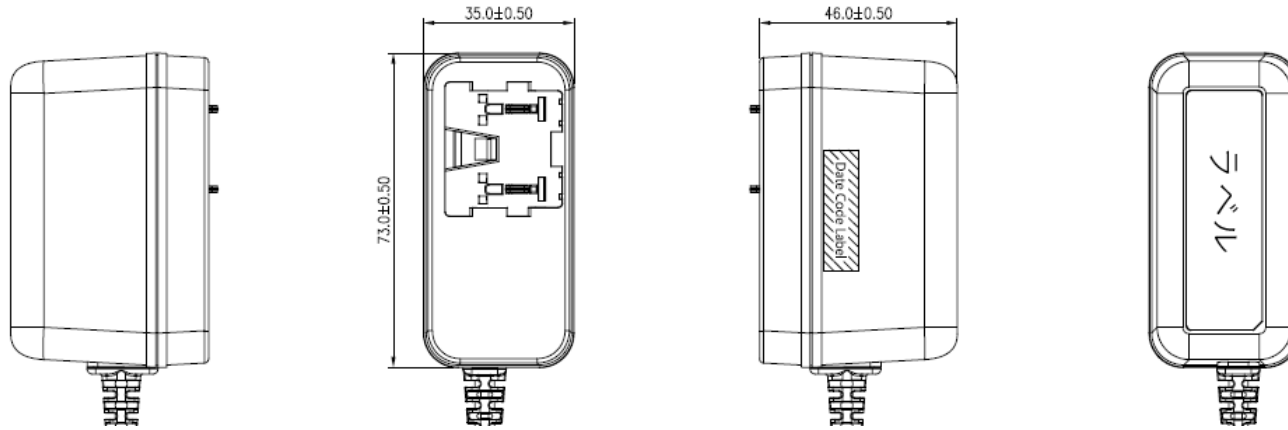

A111-3

対応国

A111-2 : USA/EU/GBR/AUS/CHN

A111-3 : USA/EU/GBR/AUS/CHN/BRA

